



U.are.U® 4000B Module

USB Fingerprint Reader Module

Target Applications

- PC peripherals, keyboards
- Kiosks, point-of-sale terminals
- Physical entry devices
- Time and attendance terminals

Features

- Small form factor
- Excellent image quality
- Encrypted fingerprint data
- Latent print rejection
- Counterfeit finger rejection
- Rugged
- Works well with dry, moist, or rough fingerprints
- Custom keyboard interface
- Compatible with Windows® XP, 2000, Me, 98, NT® 4.0 and Windows Server 2000, 2003

Key Specifications

- Pixel resolution: 512 dpi (average x, y over the scan area)
- Scan capture area: 14.6 mm (nom. width at center) 18.1 mm (nom. length)
- 8-bit grayscale (256 levels of gray)
- Module size (approximate): 57.7 mm x 35.8 mm x 11.0 mm
- Compatible with USB 1.0, 1.1 and 2.0 (Full Speed) specifications
- Indoor, home and office use

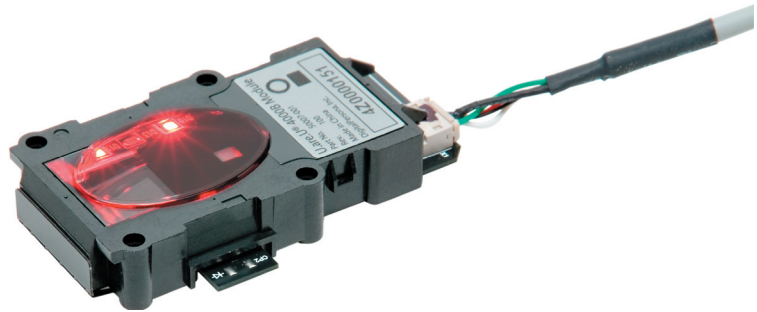

Product Description

The U.are.U 4000B Module is a miniature USB fingerprint reader designed for integration into OEM equipment where fingerprint verification is needed.

This small, self-contained module optically scans the fingerprint when the user touches the glowing window. Optical technology gives the highest quality fingerprint scans and reliability.

The U.are.U 4000B Module is designed to simplify OEM integration. The module is sealed from dust and includes convenient mounting features. The on-board electronics automatically control calibration, encryption, and data transfer over the USB interface.

The U.are.U 4000B Module and DigitalPersona® Fingerprint Recognition Engine have an unmatched ability to authenticate even the most difficult fingerprints accurately and rapidly. Digital Persona Inc.'s enterprise solutions and developer tools are perfectly suited to this device.



digitalPersona.

Mechanical Specifications

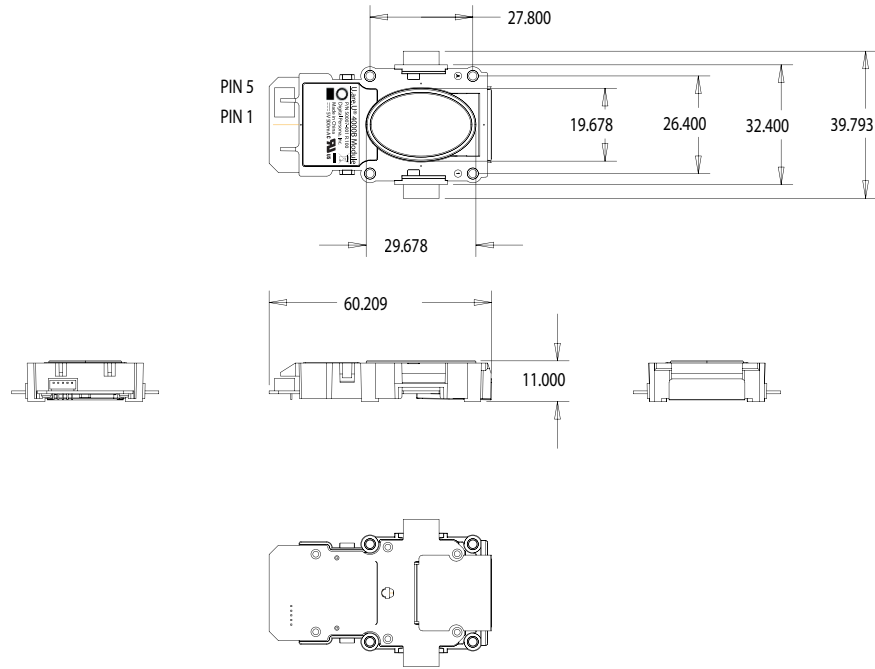

Ratings

Supply Voltage	5.0V \pm 5%
Supply Current—scanning	190 mA (Typical)
Supply Current—idle mode	140 mA (Typical)
Supply Current—suspend mode	1.5 mA (Maximum)
ESD Susceptibility	>15 kV, mounted in case
Temperature, Operating	0 - 40 C
Humidity, Operating	20% - 80% non-condensing
Temperature, Storage	-10 - 60 C
Humidity, Storage	20% - 90% non-condensing
Scan data	8-bit grayscale

Data subject to change without notice.

Connector Pinout

Pin 1:	+5V
Pin 2:	Ground
Pin 3:	Ground (shield)
Pin 4:	USB D-
Pin 5:	USB D+

Connector Type:

Hirose DF13-5P-1.25DS/equivalent

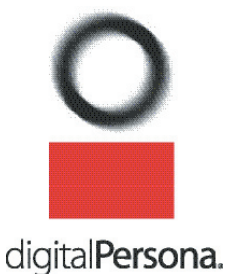

Digital Persona, Inc.
720 Bay Road, Suite 100
Redwood City, CA 94063
USA

Tel: +1 650.474.4000
Fax: +1 650.298.8313
E-Mail: info@digitalpersona.com
Web: www.digitalpersona.com

© 2005 Digital Persona, Inc. All rights reserved. DigitalPersona, and U.are.U are trademarks of Digital Persona, Inc. registered in the U.S. and other countries. All other brand and product names are trademarks or registered trademarks of their respective owners.